

VIEW ON ELEVATION
(1:10)

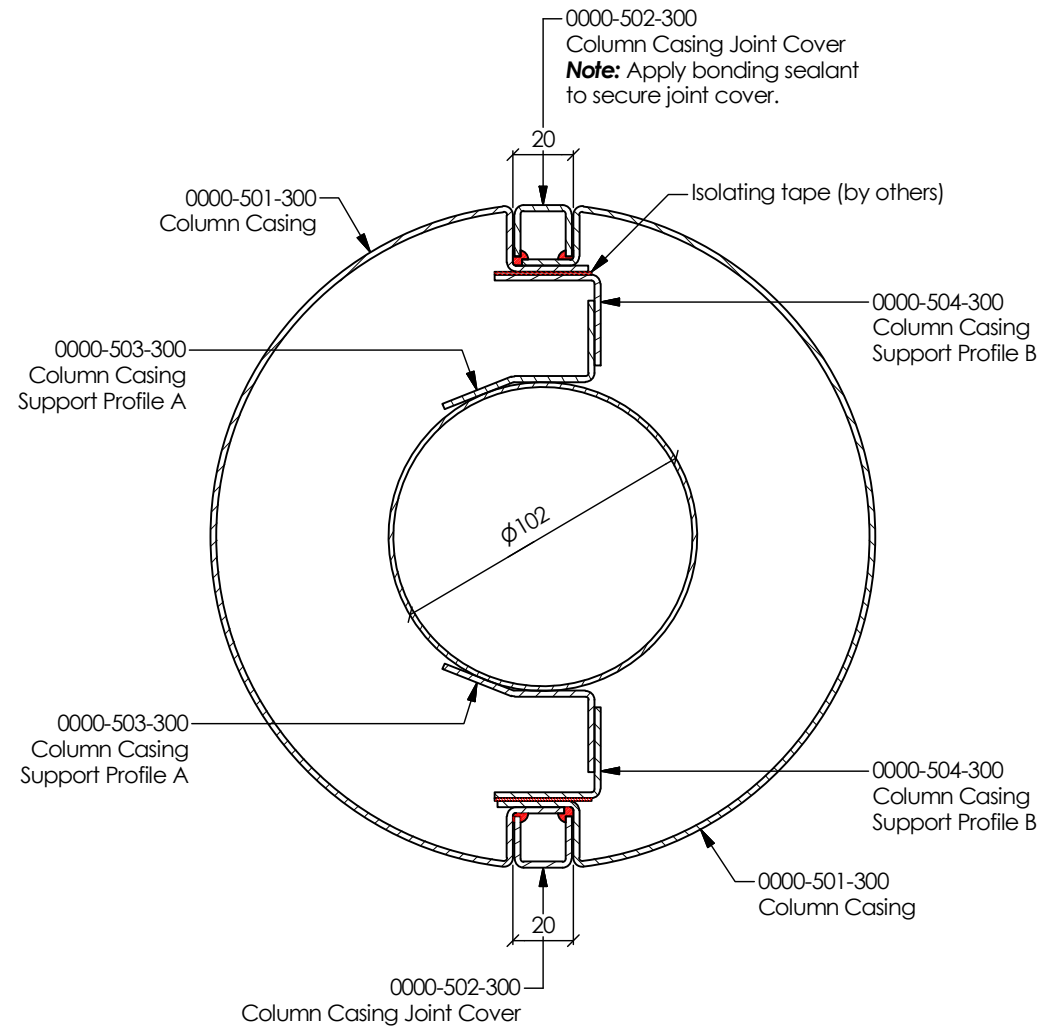

SECTION X-X
(1:2.5)

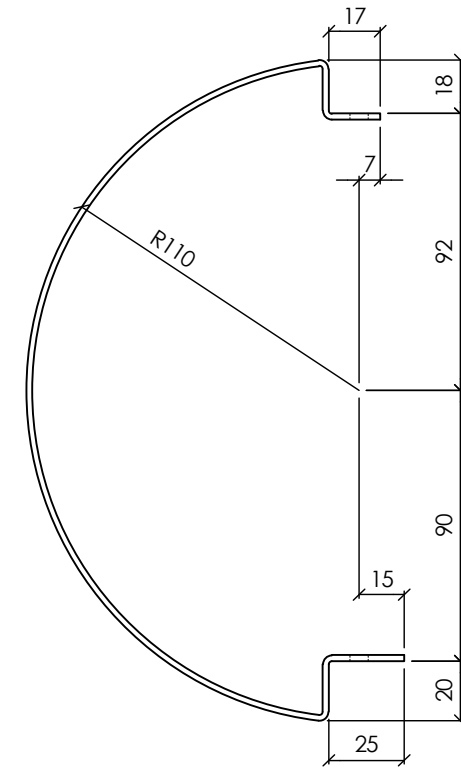

COLUMN CASING PROFILE
(1:2.5)

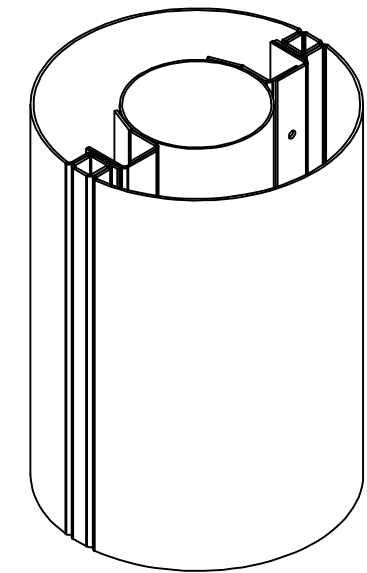

ISOMETRIC VIEW

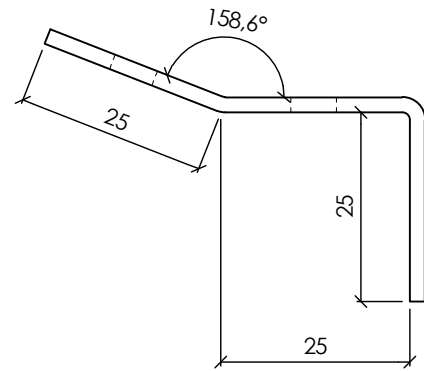

COLUMN CASING SUPPORT PROFILE A
(1:1)

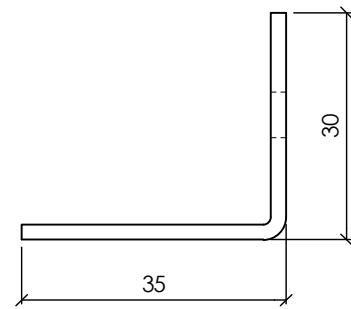

COLUMN CASING SUPPORT PROFILE B
(1:1)

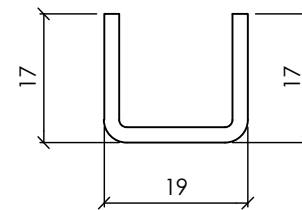

JOINT COVER PROFILE
(1:1)

PARTS LIST					
QTY	LENGTH	PART NUMBER	DESCRIPTION	MATERIAL	COLOUR & FINISH
2	300 mm	0000-501-300	Column Casing - 300mm	2.0mm Aluminium	RAL 7016 MATT
2	300 mm	0000-502-300	Column Casing Joint Cover - 300mm	2.0mm Aluminium	RAL 7016 MATT
4	300 mm	0000-503-300	Column Casing Support A - 300mm	2.0mm Galv.	MILL FINISH
4	300 mm	0000-504-300	Column Casing Support B - 300mm	2.0mm Galv.	MILL FINISH

GUTTERmaster

ALUMINIUM IN CONSTRUCTION

Shawclough Trading Estate,
Shawclough Road,
Rochdale,
Lancashire,
OL12 6ND

Tel: 01706 869550
Fax: 01706 869551

e-mail: technical@guttermaster.co.uk
web: www.guttermaster.co.uk

Client:					
Project: SAMPLE COLUMN CASING					
Title: COLUMN CASING DETAILS					
Drawing Status: ISSUE FOR APPROVAL					
Drawn by: A.S.	Checked by: A.S.	Date: 22/05/2017	Approved by:	Date:	
Sheet size: A3	Scale: as shown	Sheet No. (of sheets): 1 (of 1)	Drawing No: 0000-601	Revision:	